

WELDER TRACTORS SPW-270E

CE Approved



SPECIFICATIONS

ENGINE	
Type	CATERPILLAR C-7 ACERT
Net flywheel power (DIN 6270)	275 HP - 202 kW
Governed speed	2,000 rpm

HYDRAULIC SYSTEM	
Main pumps: Mannesmann - 2 independent variable pumps	
Maximum capacity	320 lt/min - 84 U.S. gal/min
Maximum operating pressure	400 bar - 5,800 p.s.i.

TRANSMISSION	
Type	Hydrostatic
Motors	(HYDROMATIC) two motors with axial pistons disappearing into the track frames
Brakes	Integrated negative control
Final drives	Epicycloidal oil soaked
Maximum speed	4 miles/h - 6km/hr

TRACK FRAME	
Number of bottom rollers	8 per side
Number of carrying rollers	2 per side
Length of track on the ground	3,030 mm - 119 in
Standard shoes width	610 mm - 24 in
Gauge	1,900 mm - 75 in
Track shoes	48 per side
Ground contact area	14,200 in - 36,000 cm ²
Pressure on the ground	0.66 p.s.i. - 0.30 kg/cm ²

CONTROLS	
Type	Pilot operated
Electronic steering wheel	1
Throttle lever	1
Safety lever completely bypassing the control hydraulic system	1

POWER TAKE-OFF	
Type	Hydrostatic
Control	Hydraulic
Maximum torque	551 lb/ft - 747 Nm
RPM	1,800 RPM

WELDER PACKAGES	
Automatic welder package	
Bottles box	Hydraulic
Quantity of bottles	8

ELECTRIC SYSTEM	
Operating voltage	24 V
Maintenance free supplied batteries	2
Capacity (total)	160 Ah
Starter capacity	7.5 Kw
Alternator	55 A

FLUID CAPACITIES	
Fuel tank	375 liters - 100 U.S. gal
Hydraulic system circuit	450 liters - 120 U.S. gal

HYDRAULIC BOOM	
Type	Maxilift 060.3C
Maximum lifting capacity	60 KNm
Optional	HIAB 060 hydraulic knuckle boom
Maximum lifting capacity	60 KNm

PULL HOOK	
Maximum allowed pull	
- Front	24,400 lb - 110 KN
- Rear	24,400 lb - 110 KN

DIMENSIONS

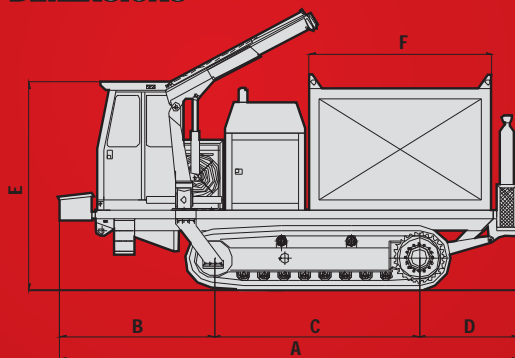

OPERATING WEIGHT 17,000 kg - 37,500 lb

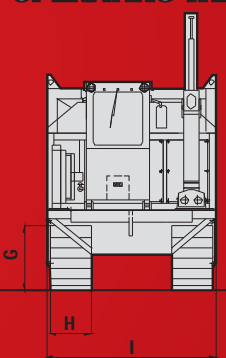

A	6.78 m / 22.25'
B	2.29 m / 7.5'
C	3.03 m / 9.9'
D	1.45 m / 4.75'
E	3.09 m / 10.1'
F	2.7 m / 8.8'
G	9.6 m / 3.2'
H	6.1 m / 2'
I	2.5 m / 8.2'

CONTACT INFORMATION & DISCLAIMER



0

PIPELINE DIVISION
